



SOIL IMPROVEMENT PRODUCT CATALOGUE.

allu.net

**ONE STEP AHEAD,
IMPROVING MORE
THAN JUST PROFITS.**

CONTENTS.

ABOUT OUR COMPANY

APPLICATIONS

ALLU PROCESSOR

ALLU PRESSURE FEEDER

PF 7 + 7 MOBILE FEEDER

ACCESSORIES AND OPTIONS

ALLU SUPPORT



ABOUT OUR COMPANY.

OVER
30
YEARS
EXPERIENCE



DISTRIBUTED
IN OVER
30
COUNTRIES



OVER
100
ALLU DEALERS
AROUND THE
WORLD

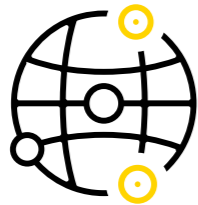

ALLU designs, manufactures and sells products for adding value to customers in numerous applications for processing different kinds of materials. Typical applications include e.g. soil and waste material recycling, processing contaminated soil, transforming waste to usable material. The history of ALLU goes back for over 30 years and today over 95% of the business is done with international customers globally. Driven by customer needs, ALLU has innovated the methods and equipment for improving the processes and operations of the customers. The serving network of ALLU consist today of own subsidiaries and a dealer network in more than 30 countries.

**OUR COMPANY
VALUES DRIVE US.**



**CUSTOMERS
FIRST**



**SAFETY IN
MIND**



**FAIR PLAY AT
HEART**

ALLU AROUND THE WORLD



HEADQUARTERS

ALLU Finland Oy

Jokimäentie 1
16320 Pennala,
FINLAND
Tel: +358 3 882 140
Fax: +358 3 882 1 440
Email: info@allu.net

NORTH AMERICA

ALLU Group Inc

25 Kimberly Road, Suite A, East
Brunswick, NJ 08816
USA
Toll Free: 800-939-ALLU (2558)
Tel: +1 732 698 7205
Fax: +1 732 307 7893
Email: usa@allu.net

ALLU SALES OFFICE MIDDLE EAST

Tel: +614 3499 0368 (Australia)
Email: me@allu.net

GERMANY

ALLU Deutschland GmbH

Maschweg 77
DE-49324 Melle
GERMANY
Tel: +49 (0) 5422 / 92782 - 0 (Zentrale)
Fax: +49 (0) 5422 / 92782 - 15
Email: deutschland@allu.net

SWEDEN

ALLU Sverige AB

Stenvretsgatan 1,
SE-749 40 Enköping,
SWEDEN
Tel: +46 (0)171-17 15 17
Email: sverige@allu.net

FRANCE

ALLU France S.A.R.L.

180 ZA les Bruottées
21200 VIGNOLES,
FRANCE
Tel: +33 3 80 24 04 34
Fax: +33 3 80 24 04 36
Email: france@allu.net

CHINA

ALLU China Co., Ltd

阿陆环保科技 (昆山)
有限公司
No.4 Factory, No. 639 Yide
Road, Zhangpu Town 215300
Kunshan, P.R. CHINA
Tel: +86 21 5888 5836
Fax: +86 21 5888 5801
Email: china@allu.net

APPLICATIONS.

ALLU Soil Improvement is versatile, efficient and cost-efficient material mixing and soil stabilization technology. It's equipment you'll wish you'd found sooner.



CIVIL
ENGINEERING

FOUNDATION

Bearing capacity improvement of poor-quality soils by mixing, adding binder and stabilizing.

1. Residential areas
2. Dredging and harbour construction
3. Railway and road construction



1.



2.



3.

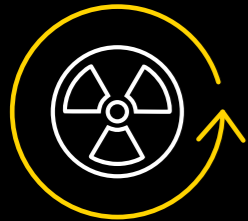

CONTAMINATED
SITES REMEDIATION

REMEDIATION

Purifying or neutralization process by mixing and adding binder or additives to contaminated soil or waste material.

1. Liquid waste lagoons
2. Oil spill and acid tar
3. Contaminated soil



1.



2.



3.



COASTAL
FACILITIES

SOLIDIFICATION

Transforming very soft soil or liquid material into solid form by mixing and adding binder.

1. Temporary roads
2. Mine tailings
3. Excavation work



1.



2.



3.

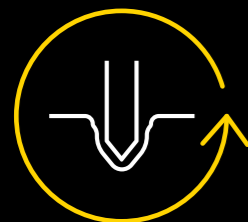

SOLIDIFICATION

ALLU PROCESSOR.



SPECIAL FEATURES

Patented V shaped mixing head

- Minimal "blind spot" between the auger shaped mixing drums
- Increases soil penetration capability
- Increases mixing capability
- Changeable wear parts



**IT REACHES.
IT MIXES.
IT PROCESSES
DRY OR WET.**



PROCESSOR.™

The ALLU Processor is a power mixer hydraulic attachment for excavators. This attachment converts the excavator into a powerful and versatile mixing tool, capable of penetrating and mixing a variety of difficult materials - everything from clay, silt, peat and dredged sediments to hazardous liquid waste and contaminated soil.

The ALLU Processor mixer is linkable to any type of binder feed - wet or dry.

ALLU PROCESSOR 300HD

TECHNICAL SPECIFICATIONS

Working depth	3 m / 10 ft
Hydraulics	Max. pressure: 350 bar (5000 psi) Max. flow: 300 l/min (79 gallon US/min) Max. power: 160 kW
Torque	Max: 12 000 Nm / drum at 350 bar
Weight	2 400 kg (5 300 lbs.)
Base machine	25 - 45 ton (55 000 - 99 000 lbs.)

ALLU PROCESSOR 500HD

TECHNICAL SPECIFICATIONS

Working depth	5 m / 16 ft
Hydraulics	Max. pressure: 350 bar (5000 psi) Max. flow: 300 l/min (79 gallon US/min) Max. power: 160 kW
Torque	Max: 12 000 Nm / drum at 350 bar
Weight	2 800 kg (6 000 lbs.)
Base machine	25 - 45 ton (55 000 - 99 000 lbs.)

ALLU PROCESSOR TRANSMISSION

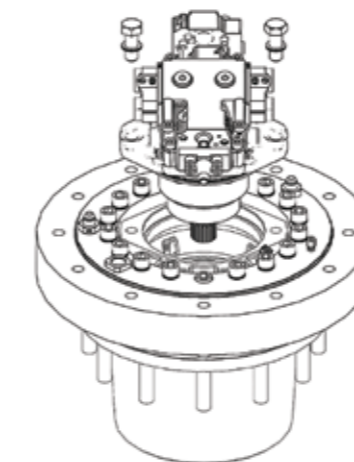

HIGH SPEED HYDRAULIC MOTOR

- Displacement 80 cm³
- 3125 rpm @ 250 L/min
- 3750 rpm @ 300 l/min

PLANETARY GEAR

- Gear ratio 1:31.8
- Nominal torque 18 000 Nm / drum
- Maximum torque 25 000 Nm / drum (theoretical)

MIXING DRUM SPEED: MIN 25 RPM – MAX 100 RPM

ALLU PRESSURE FEEDER.



ENGINE - Stage V / Tier4F

Power	110 kW / 2 200 rpm
Torque	560 Nm / 1 400 rpm
Fuel tank	400 l (105.6 gallons US)

COMPRESSOR

Type	Screw compressor
Max. pressure	10 bar (145 psi)
Min. pressure	3 bar (43.5 psi)
Power	75 kW
Output with working pressure	11,7 m ³ (15,30 yd ³ / min)

**IT FEEDS. IT CONTROLS.
IT REPORTS
WITH PRECISION.**

The mobile ALLU Pressure Feeders are high capacity, tracked, intelligent feeding units for dry binders. The computer-controlled binder feed prevents any unnecessary amount of binder to be feed. This unique feature brings big cost savings and efficiency to any jobsite.

PF7 + 7 DOUBLE TANK UNIT

TECHNICAL SPECIFICATIONS	
Weight (1. empty - 2. full)	1.) 22 000 kg (48 500 lbs.) 2.) 38 500 kg (84 878 lbs.)
Tank volume	2 x 7 m ³ (2 x 9,15 yd ³)
Max. operational pressure	10 bar (145 psi)
Ground pressure (1. full 800 mm track shoe - full 500 mm track shoe)	1.) 0,68 kg / cm ² 2.) 1,02 kg / cm ²
Adjustable. binder feed capacity	3 - 15 kg / sec. (6,6 - 33 lbs.)
Binder granulate specification	0 - 2 mm (0 - 0,78 inch)
Max. feed distance (1. 3-inch hose - 2. 2-inch hose)	1.) 200 m (218 yd.) 2.) 100 m (109 yd.)
Feed control & reporting system	ALLU DAC.2.1
Hydraulics	Hydraulically operated compressor, rotary valve and process valves
Dimensions L x W x H	6870 x 3400 x 3300 mm (22,53 x 11,15 x 10,82 ft.)

PF 7+7

**MOBILE FEEDER FOR
DEEP DRY MIXING.**



**LIME /
CEMENT
COLUMNS.**

The Allu PF 7+7 is a self-contained mobile feeder for deep dry mixing, the track driven feeder is completely road legal and easy to transport on a low bed trailer making it extremely mobile. Fast setup on jobsite results in less down-time and the large air capacity gives improved productivity.

SPECIAL FEATURES

- Remote controlled for safe and easy loading and unloading
- Maximum column depth 30 m (98 ft.)
- Long feed distance (max 200 m (656 ft.)) Adjustable feed rate
- Can bus control system
- Easy feed data access and transfer to outside control system

ACCESSORIES AND OPTIONS.

The maximum mixing depth can be increased by adding an extension to the Processor attachment. The available extensions are easily installed or removed by “plug and play”.

PROCESSOR EXTENSIONS

2 m EXTENSION

Weight	770 kg (1 700 lbs.)
Length	2m (7 ft.)
Max. mixing depth 300HD + extension	5 m (16 ft.)
Max. mixing depth 500 HD + extension	7m (22 ft.)

3 m EXTENSION

Weight	950 kg (2 100 lbs.)
Length	3m (9 ft.)
Max. mixing depth 300HD + extension	6 m (19 ft.)
Max. mixing depth 500 HD + extension	8m (26 ft.)

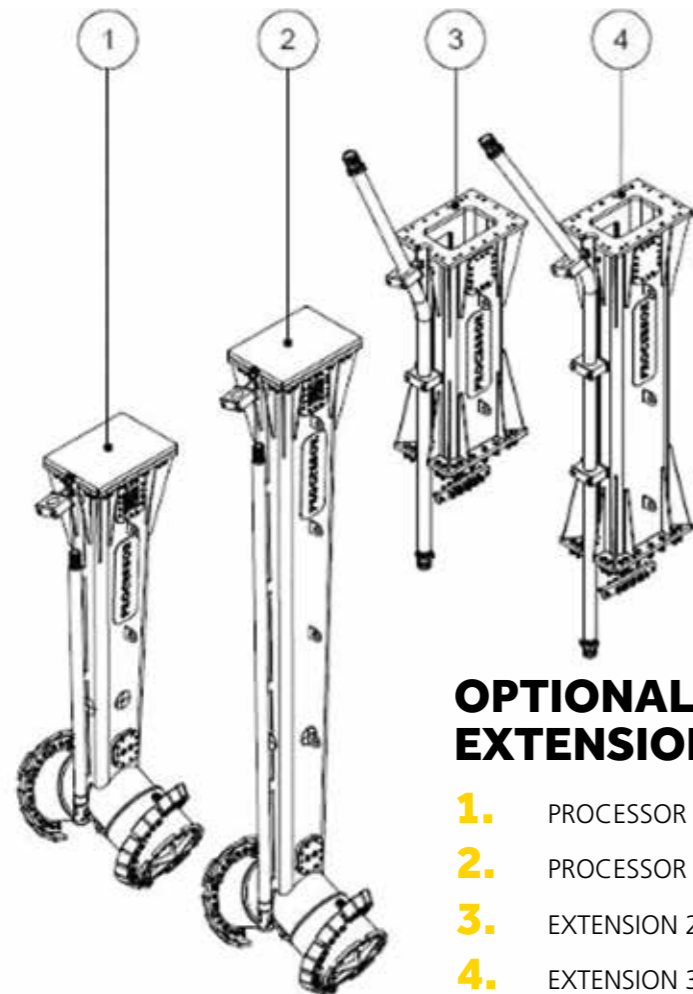

OPTIONAL BOLT ON EXTENSIONS

- 1.** PROCESSOR 300 HD – 3 m (10 ft)
- 2.** PROCESSOR 500 HD – 5 m (16 ft)
- 3.** EXTENSION 2 m (6,5 ft)
- 4.** EXTENSION 3 m (10 ft)





SUPPORT.

The ALLU Soil Improvement products doesn't just come with inbuilt efficiency. They also comes with unrivalled aftersales support. No matter what the issue, our team is on hand to offer all the help you need in getting the most out of your equipment. We're just a phone call or email away.

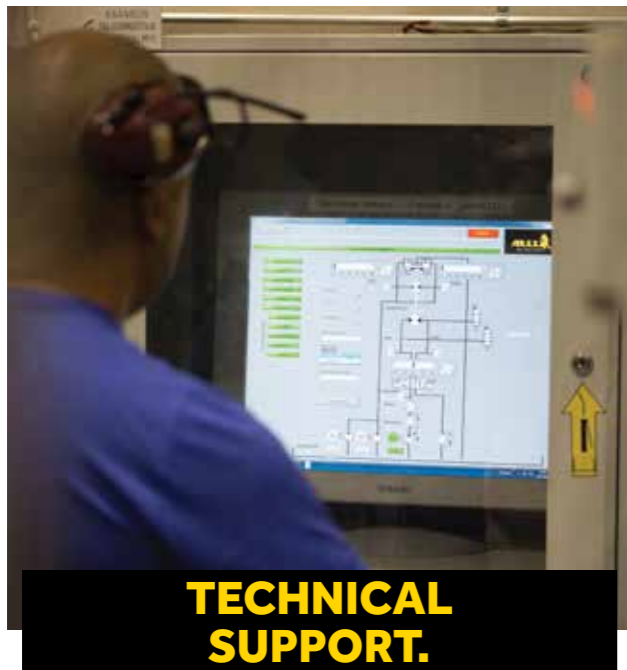

TECHNICAL SUPPORT.

Having built the unique Soil Improvement technology, there's no one better than our technical experts to offer their support. From getting started for the first time, to pushing your soil improvement products to their limits, we can freely advise. It's very unlikely that anything will go wrong with your equipment, but it's good to know we're here all the same.



TRAINING.

By providing training and sharing our information we can help to improve the skills of your workforce and advance the industry as a whole. Overseen by our highly-experienced team, we help you to achieve maximum levels of efficiency through technical improvement, new technology and enhanced operating practices.

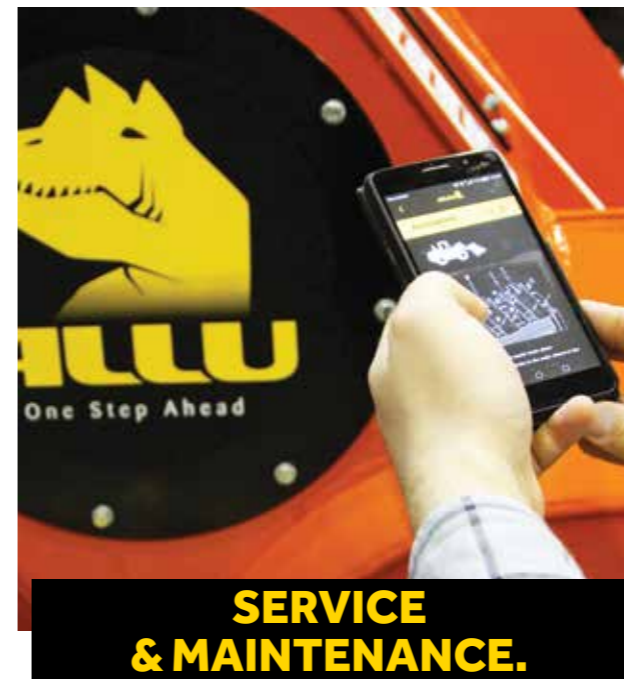

SERVICE & MAINTENANCE.

To complement our unique soil improvement equipment, we offer a wide selection of service and maintenance procedures. Whether it's inspection or troubleshooting, the ALLU team is always happy to lend their support. And with planned preventative maintenance, customers can get all the advice needed to keep their machines fully optimised and working at maximum capacity.



REFURBISHMENT.

Why replace your equipment when you refurbish or repair it. No equipment is faultless, but sometimes it's only a small part that needs attention. A little fine-tuning here. The odd upgrade there. And that's where we'll help. At ALLU, we're all for saving our customers money. Your business is our business – and we're determined to see you right.

**OUR GLOBAL TEAM
IS HERE TO HELP YOU
ACHIEVE YOUR SOIL
IMPROVEMENT GOALS.**



ALLU.NET

ALLU Group

Jokimäentie 1, 16320 Pennala, Finland

Tel: +358 3 882 140

Email: info@allu.net

